



ATM 330.2

ATM 440.2

ATM 550.4

ATM 660.4

ATM COMPACT CLASS A/B AMPLIFIER
Owners Manual

Please read through this manual to familiarize yourself with your new amplifier. Should your PowerBass AutoSound mobile amplifier ever require service, you will need to have the original dated receipt.



Thank you and Congratulations

Thank you for your decision to purchase a PowerBass USA Autosound mobile amplifier! Our Autosound amplifiers are the result of extensive engineering, testing, and bullet proof construction. Their versatility enables compatibility with optional signal and audio processors. These high quality MOSFET amplifiers may be configured to allow maximum flexibility in designing different types of speaker systems.



COMPACT A/B CLASS FULL RANGE AMPLIFIERS

The PowerBass Atom Series are high quality MOSFET amplifiers that are capable of running a system full range, or they may be selected only to power subwoofers. It is important that you closely follow the wiring instructions contained in this Owners Manual so that you get the most from your PowerBass AutoSound mobile amplifier.

Δ Caution Δ

High powered audio systems in a vehicle are capable of generating higher than "Live Concert" levels of sound pressure. Continued exposure to excessively high volume sound levels will cause hearing loss or damage. Also, operation of a motor vehicle while listening to audio equipment at high volume levels may impair your ability to hear external sounds such as horns, warning signals, or emergency vehicles—thus creating a potential traffic hazard. In the interest of safety, PowerBass USA highly recommends listening at lower volume levels when driving.

TECHNICAL FEATURES

- Low Profile Aluminum Finned Heatsink
- High and Low Level Line Inputs
- Double Sided Circuit Board Construction
- PWM MOSFET Power Supplies for High Power Output and Best Stability into Low Impedance Loads
- Variable High Pass and Low Pass Electronic Crossover
- Soft Delay Remote Turn On/Off Circuit to Eliminating Pops and Clicks
- Selectable Bass EQ at 40Hz (0, 6 or 12dB)
- Self Diagnostic Multi Protection Circuit with LED Status Indicator for; Impedance Over-load, Speaker Short Circuit, Thermal Overheating, and DC Output.
- 2-ohm Stereo Stable (4-ohm Mono Bridgeable)
- Custom Tooled Solderless Speaker and Power Terminal Blocks
- Variable Gain Control
- Fan cooled (ATM 550.4 and ATM 660.4 only)

INSTALLATION EXPERIENCE

Installation of PowerBass mobile amplifiers requires detailed knowledge of electronics wiring and proper speaker impedance. We strongly recommend installation by an authorized PowerBass dealer. This Owners Manual only provides general installation and operation instructions. If you have any reservations about your installation skills, please contact your local PowerBass dealer for assistance.

IMPORTANT : This amplifier is designed for operation in vehicles with 12-volt Negative ground electrical systems only.

PREPARING FOR INSTALLATION

NOTE: The tools listed below may be required for basic installation

- An electric drill with bits
- Philips head and standard screwdrivers
- Wire strippers
- Crimping tool
- VOM (electronic volt ohm meter)
- Heat shrink tubing and heat gun
- Soldering iron
- Electronic (not Acid Core) Solder

INSTALLATION PRECAUTIONS

NOTE: Proceed only if you are a qualified installer, otherwise; see your Authorized PowerBass Dealer to professionally install this amplifier. Always wear protective eyewear when using tools.

- Turn off all stereo and other electrical devices before you begin.
- Disconnect the negative (-) lead from your vehicles battery.
- Locate all fuel lines, brake lines, oil lines, and electrical cables when planning the install.
- Make sure there is at least 2-inches (5 cm) around the air vents on the amplifier.
- When connecting ground points, make sure all paint is carefully scrapped away from the chassis and contact is made with bare metal.
- Use a utility knife to trim away fabric from hole locations before drilling or cutting.
- When running power cables through sheet metal, be sure to use grommets to properly insulate the metal edges from the wire insulation.
- If possible, use tubing through grommets.

MOUNTING THE AMPLIFIER

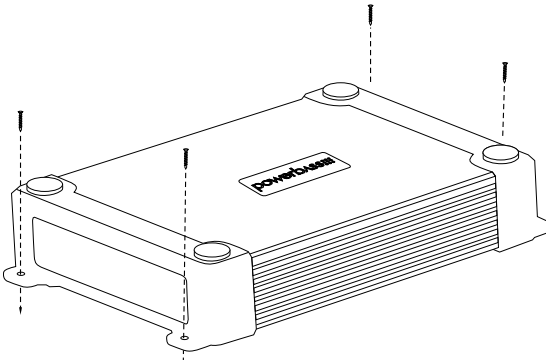

Fig.1 Mounting Amplifier

To keep your PowerBass Atom amplifier running at top performance, choosing the proper location is of utmost importance. For this reason the amplifier should be mounted in a location which will allow air to circulate freely. A clearance of at least 2-inches (5 cm) to all sides of the amplifier is necessary not only for proper cooling, but also for gaining access to the inputs and other variable controls. Be sure that the power and signal cable connections can enter and leave the amplifier in a straight line to avoid the risk of kinked wires causing malfunction.

MOUNTING LOCATION

Find a clear and well ventilated area to mount your amplifier that is unobstructed by any objects that will cause harm or block ventilation. You may use the amplifier as a template and mark the four screw locations with a felt tip pen. Set the amplifier aside before drilling. Use caution to make sure there are no objects behind the installation surface that may become damaged during drilling.

If mounting under a seat, make sure there is at least 1-inch (2.5 cm) of space above the amplifier's heatsink to permit proper cooling.

The amplifier should be protected from exposure to moisture and direct sunlight. The best places to mount your amplifier are: The floor of the trunk, under a seat, or on the back of the rear seat. For alternate installation locations, please consult your authorized PowerBass Dealer.

NOTE: Do not use a drill with driver bit to mount the amplifier. Excessive force could cause the plastic mounting feet to crack.

*** WARNING ***

- Do not install in a place where it could injure the driver or passengers if the vehicle stops suddenly.
- Upside down mounting will compromise heat dissipation through the heatsink and could engage the thermal protection circuit.
- Try to avoid mounting the amplifier on a subwoofer enclosure, as extended exposure to vibration may cause malfunction of the amplifier.
- Don't mount the amplifier so that the wire connections are unprotected or are subject to pinching or damage from nearby objects.
- The DC power wire must be fused at the battery positive (+) terminal connection. Before making or breaking power connections at the amplifier power terminals, disconnect the DC power wire at the battery end.
- The battery of the car audio system must be disconnected until the entire wiring and installation is completed.
- Don't use a power drill to tighten the power, ground, remote or speaker output terminals on the amplifier to avoid stripping the terminal screws. It is best to hand tighten these connections.

CONTROL PANEL LAYOUT

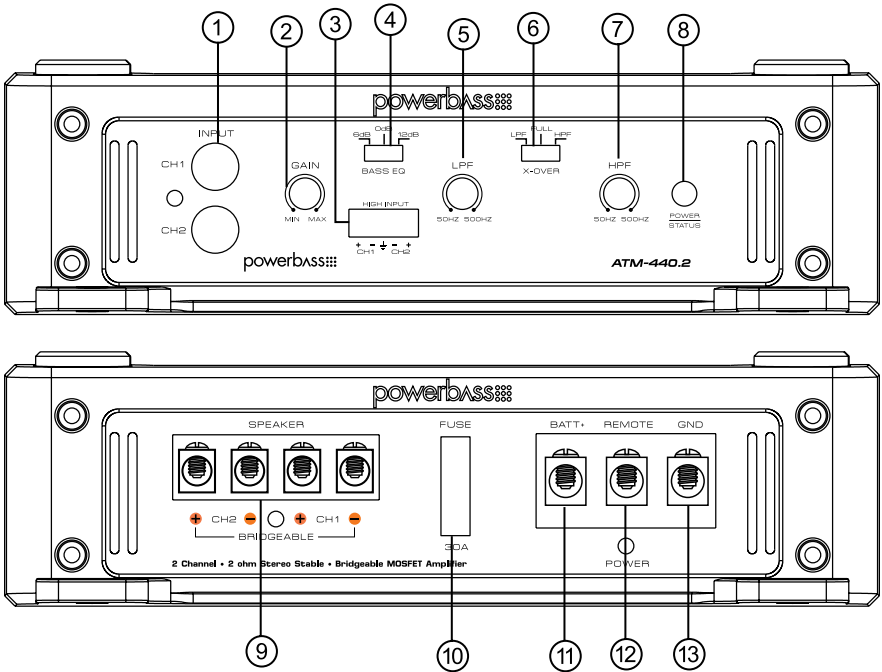

Fig.2 Panel Layout

NOTE: Panel Layout and Controls may differ by model.

1. Line INPUT (RCA) Jacks

These RCA style input jacks are for use with source units that have RCA line level outputs. A source unit with a minimum output of 200mV is required for proper operation. However, this input will accept levels up to 5Vrms.

2. GAIN Control

This control is used to match the input sensitivity of the amplifier to the particular source unit that you are using.

3. HIGH INPUT

Allows you to connect speaker output from factory radio to amplifier without the use of a low level convertor.

4. BASS EQ Switch

This equalization circuit is used to enhance the low frequency response of the vehicle's interior. Selectable for 6 or 12dB of boost centered at 40Hz, the BASS EQ can be adjusted to meet your own personal taste.

5. LPF (Low Pass Filter) Control

This control is continuously adjustable from 50Hz through 500Hz at 12dB per octave.

6. X-OVER Switch for FULL/HPF/LPF

Activates the built in electronic crossover network. Works in conjunction with the HPF and LPF adjustable controls.

7. HPF (High Pass Filter) Control

This control is continuously adjustable from 50Hz through 500Hz at 12dB per octave.

8. POWER/STATUS Indicator

The clear LED turns BLUE when the power is on. Should the LED turn RED this is an indicator there is a problem with the system in relation to the amplifier (see Troubleshooting Tips).

9. SPEAKER Output Terminals

As shown in the wiring diagrams, be sure to observe speaker polarity through the system and speaker impedance. This specially tooled solderless terminal is designed to accommodate up to 10 gauge speaker wire.

10. FUSE

For convenience most PowerBass AutoSound amplifiers utilize common automotive ATC type fuses. For continued protection in the event that a fuse blows, replace the fuse only with the same value. (See specification tables)

11. BATT+ (Power Input Connection)

This terminal is the main power input for the amplifier and must be connected directly to the positive (+) terminal of the car battery. This specially tooled solderless terminal is designed to accommodate up to 4 gauge power wire. (see Power Cable Selection Chart for recommended wire gauge for each model)

12. REM (Remote Input Connection)

All PowerBass AutoSound amplifiers can be turned on by applying 12 volts to this terminal. This can be found on the rear of the source unit in the form of an electric antenna output, or a remote output. If this is not available you can wire to the ACC position on the key. An 18 gauge wire is sufficient to run the REMOTE.

13. GND (Ground Input Connection)

A good quality ground is required for your PowerBass AutoSound amplifier to operate at peak performance. A short length of cable the same gauge as your power cable should be used to attach the ground terminal directly to the chassis of the vehicle. Make sure that all of the paint is sanded or scraped away to ensure a quality ground connection.

POWER WIRING AND SIGNAL CONNECTIONS

*** WARNING ***

Disconnect the negative (-) battery terminal before you start any wiring work! The battery of your car audio system must be disconnected until the entire wiring installation is completed.

Your PowerBass Autosound amplifier requires unrestricted current to deliver peak performance, so do not “starve” your amplifier by using small power cable. Using under sized power cable can result in unnecessary over-heating of the amplifier, distortion at high volume levels and might even cause the thermal protection circuitry to shut-off the amplifier. For best results we recommend a PowerBass amplifier install kit, available at your local PowerBass dealer.

- Use rubber grommets when running cables through any metal or sharp plastic, to prevent accidental shorting or shearing. Make sure the cables do not interfere with normal operation of the vehicle.
- The audio signal cables (RCA interconnects) should be kept far away from any potential sources of electrical interference such as electronic vehicle management systems (relays, engine computers etc.), wiring harnesses, fuel pumps etc.

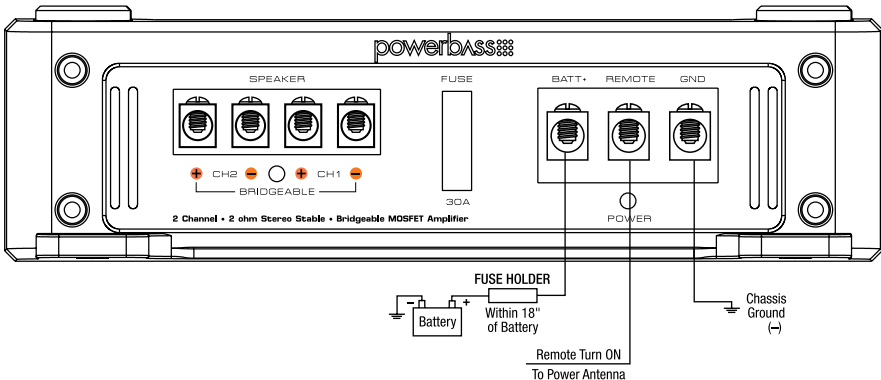

Fig.3 Power Input Connection

These amplifiers are designed to work within a 10 to 16.5 volt DC range. Before any wires are connected, the vehicles electrical system should be checked for correct voltage supply with the help of a voltmeter.

First, check the voltage at the battery with the ignition in the OFF position. The voltmeter should read no less than 12V. If your vehicles electrical system is not up to these specifications, we recommend having it checked by an auto electrician before any further installation. Once the vehicle is checked, make certain the correct cable gauge is used. We recommend using as large a gauge cable as possible, use the Power Cable Selection Chart to calculate the correct power wire size for your application. Remember Bigger is Better!

POWER WIRING

BATT+ (Power)

This amplifier should be wired directly to the vehicle battery using the appropriate size cable. Start at the vehicle battery and run the power cable through to the amplifier. Avoid running the power cable over engine components and near heater cores. The use of an inline fuse or circuit breaker is a must; this will prevent the risk of a potential fire caused by a short in your power cable. Connect the fuse holder or circuit breaker as close to the battery positive (+) terminal as possible (no farther then 18" from the battery). This fuse or circuit breaker should be no greater then the sum of the fuses found on the chassis of your amplifier (also see specifications chart). You may now connect the cable to the battery, but remember to leave the fuse out or circuit breaker "off" until all other cable connections are made.

GND (Ground)

When grounding your amplifier, locate a metal area close to the amplifier that is good source of ground (preferably the floor pan). Once again, investigate the area you wish to use for electrical wires, vacuum lines, and brake or fuel lines. Use either a wire brush or sandpaper to eliminate unwanted paint for better contact of the ground.

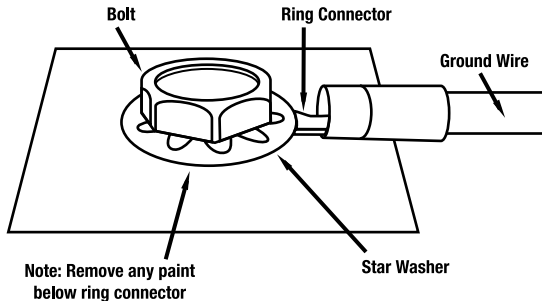

Secure the ground cable to the body using a bolt, star washer and nut. Spread silicon over the screw and bare metal to prevent rust and possible water leaks.

Now it's time to connect the power and ground cables to the amplifier. Cut both cables to length. Strip off 1/2 inch (12mm) of the insulation so that the bare wire fits all the way in the terminal block on the side panel of the amplifier, seating it firmly so no bare wire is exposed. Use a screw driver to loosen the BATT+ and the GND connection on the amplifier. Insert the ground first, and then the +12V and please make sure that you place them into the correctly marked terminals. Hand tighten the set screws and make sure the connection is secure to prevent possible arcing due to loose screws.

REM (Remote Trigger)

This terminal must be connected to a switched +12V source. Typically, remote turn-on leads are provided at the source unit that will turn on and off the amplifier in correspondence with the source. If the source unit does not have a remote turn-on lead, then a power antenna wire can be used. If neither of these leads is available at the source unit, then a switched +12V supply must be used, like the ACC, +12V.

Run a minimum of 18 gauge wire from the amplifier location to the source of the switched +12V lead. If possible, route this wire on the same side of the vehicle as your power cable. Connect the source remote output to the wire. Go back to the amplifier and cut the wire to length. Loosen the screw terminal marked REMOTE on the amplifier using a Phillips (cross) type screwdriver. Insert the stripped (bare) portion of the wire into the terminal and tighten the screw securely.

NOTE: It is highly recommended that a hand screw driver and NOT a power drill is used to tighten the set screws on the terminal blocks. This will prevent stripping or other possible damage to the amplifier.

RCA INTERCONNECT WIRING

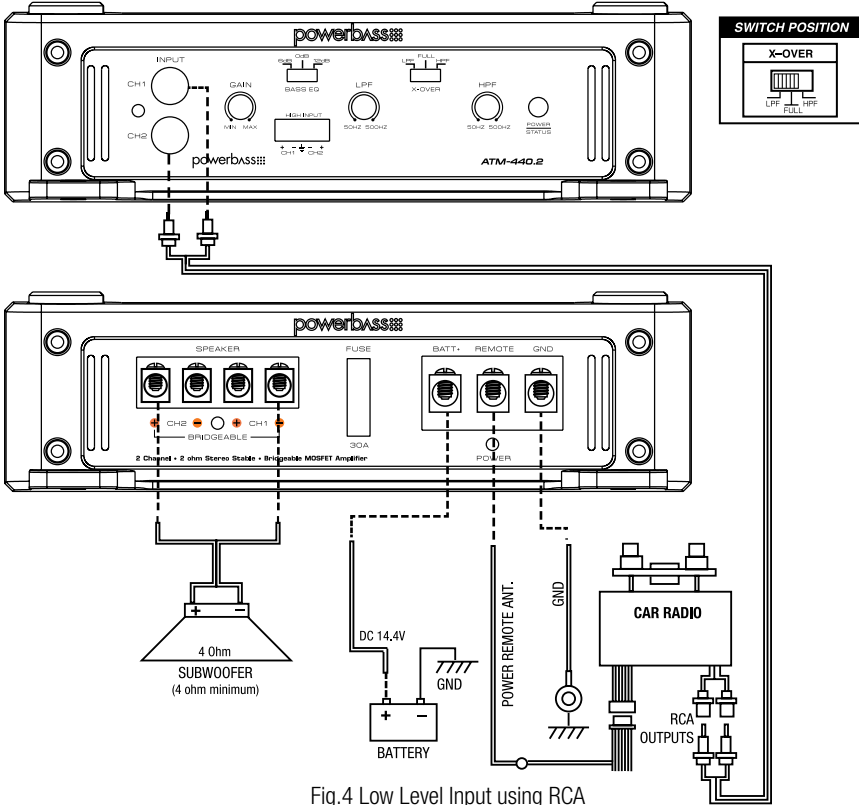

Fig.4 Low Level Input using RCA

Choose the correct length and style of RCA interconnects for your needs. Always use high quality RCA audio cables (not supplied) for signal connections—those with multiple layers of shielding or a twisted pair variety provides better noise rejection.

Be extra careful when routing your RCA audio interconnect cables. Car environments are notorious for poorly insulated wires. This means that hiss, engine noise, and fan noise can easily be picked up through RCA cables if run incorrectly.

Make sure that the cables for power and audio signal are not on the same side of the vehicle and that they do not cross each other; this will help reduce any noise that may radiate from the power cable and the signal cable. If an audio cable is too close to a power cable, it may pick up the magnetic field generated by the power cable, which could lead to a loss of quality in your signal.

HIGH LEVEL CONNECTIONS (Optional)

High Level inputs have been included to connect the amplifier to a radio without low-level outputs (i.e. factory radio). This plug-in terminal will allow you to connect directly to the speaker output of the radio without the need of an external adapter.

Determine the type of radio you have and make one of the following connections. Do not use the High Level inputs if you have already wired the Low Level Inputs.

CAUTION! Before making any connections determine the type of radio to avoid possible damage to amplifier and/or radio.

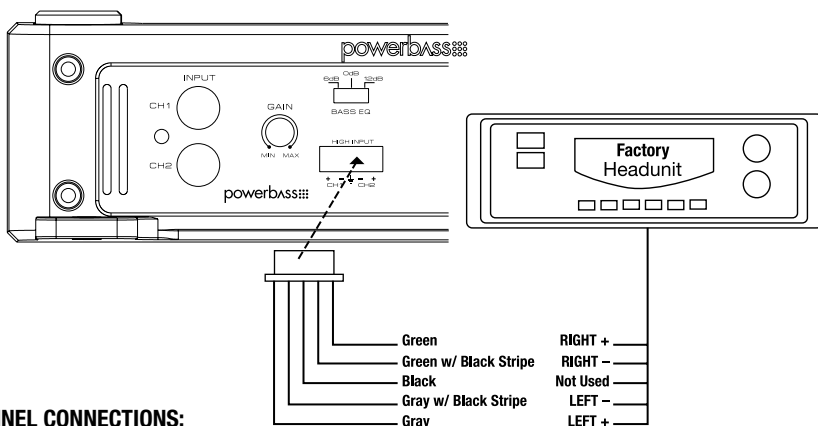

**TWO CHANNEL CONNECTIONS:
FLOATING GROUND RADIO (MOST POPULAR TYPE)**

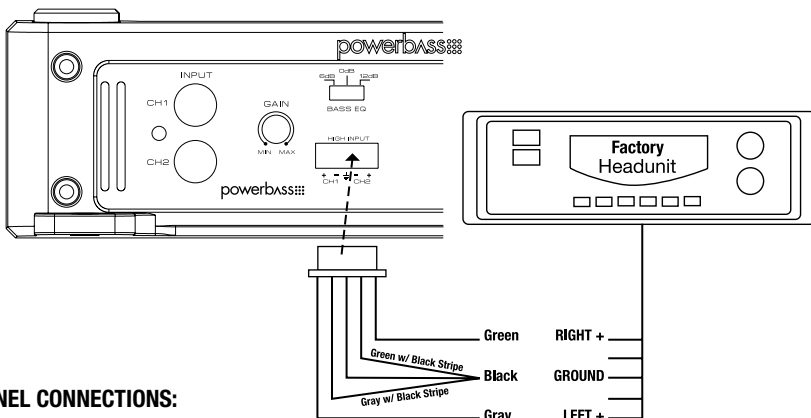

**TWO CHANNEL CONNECTIONS:
COMMON GROUND RADIO (RARE TYPE)**

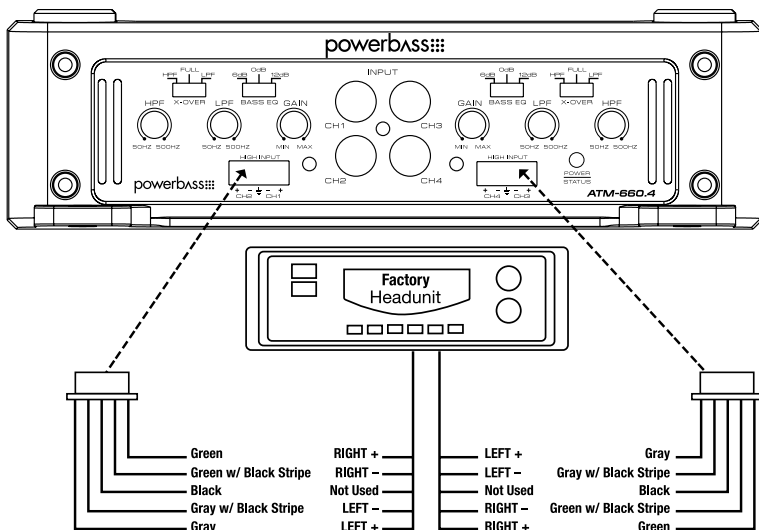

**FOUR CHANNEL CONNECTIONS:
FLOATING GROUND RADIO (MOST POPULAR TYPE)**

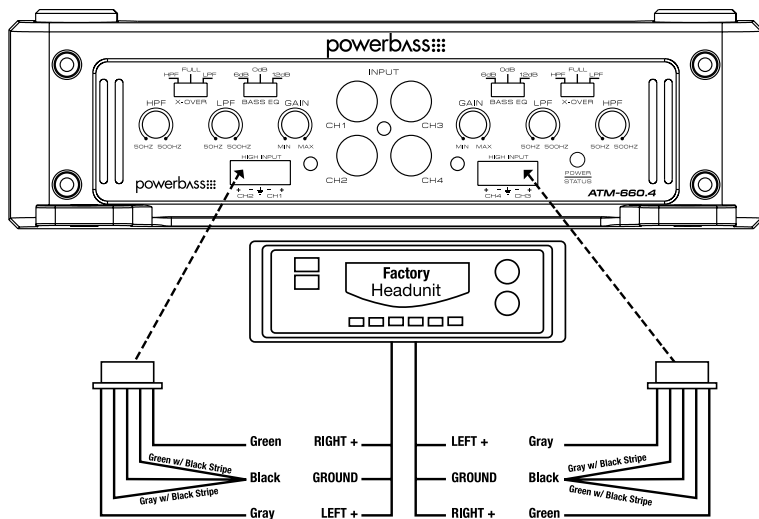

**FOUR CHANNEL CONNECTIONS:
COMMON GROUND RADIO (RARE TYPE)**

SET UP ADJUSTMENTS

Input Gain Adjustment



Input Sensitivity Control

Fig.5 GAIN Control

This control allows you to match the input level of the amplifier to the output level of your head unit. Matching the input can be accomplished in three simple steps:

1. Set the volume of GAIN on the amplifier to Min (completely counter clock wise).
2. Turn on the head unit and adjust volume to 2/3 maximum, and set the BASS and TREBLE to zero.
3. Adjust the GAIN control clockwise until the sound **just begins** to distort, then back off slightly to cut distortion and operate at optimum gain.

Remember, the **GAIN control is not a volume control**. Ignoring the three steps above may leave you with damaged speaker and/or a damaged amplifier.

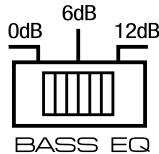

Fig.6 Bass EQ Control

Bass EQ Switch

This special feature is designed to provide you more powerful sound quality, and it allows you to boost the Bass EQ to either 6 or 12dB. Keep in mind that more is not always better. Setting the control to the max (12dB) will stress the amplifier and the speakers and could result in damage.



Fig.7 High Pass Control (HPF)

HPF (High Pass Filter) Adjustment

When you are using coaxial or component speaker system, this allows you to adjust high-pass X-over frequency from 50Hz to 500Hz. To get better sound quality from coaxial or component speaker system, we recommend the frequency should be higher than 65Hz. Make sure the X-OVER switch is positioned at "HPF".



Fig.8 Low Pass Control (LPF)

LPF (Low Pass Filter) Adjustment

Using this volume, adjust the LPF frequency for your subwoofer speaker(s) operation. The X-OVER switch position should be at “LPF”.

SPEAKER WIRING AND CONFIGURATIONS

Speaker Load

Keep in mind your PowerBass Autosound amplifier is a high power amplifier and not a high current amplifier. In other words **this amplifier requires a minimum impedance of 2 ohms STEREO and 4 ohms bridged MONO to operate trouble free.** Lower impedance will send the amplifier into protection and may possibly damage the electronics inside.

Speaker Wiring

Choose the correct speaker wire for your application. Most applications will require a minimum of 16 gauge wire. Route these using the same precautions as you did when you ran the power cable. Terminate these wires at the speaker end using insulated speaker terminals (not supplied) or by soldering the connection. Make sure the speaker connections are positive-to-positive and negative-to-negative. At the amplifier end, At the amplifier end, it is very important that the wires are making solid contact. Strip the wires insulation back approximately 1/2 inch (12mm) and insert the wires into the appropriate openings. Check to make sure you've maintained proper polarity and balance.

NOTE: It is highly recommended that a hand screw driver and NOT a power drill is used to tighten the set screws on the terminal blocks. This will prevent stripping or other possible damage to the amplifier.

CAUTION:

Maintaining proper impedance is critical when wiring the Class AB model amplifiers. Improper wiring can cause severe damage to BOTH the woofer and the amplifier. Detailed wiring diagrams are supplied with all PowerBass woofers. IF YOU ARE NOT EXPERIENCED OR UNCOMFORTABLE READING THE WIRING DIAGRAMS CONSULT YOUR AUTHORIZED POWERBASS DEALER BEFORE YOU ATTEMPT TO WIRE THE SYSTEM.

Speaker Output Connections 2 Channel Models (ATM-330.2 & ATM-440.2)

1. 2-Channel Speaker Output Connection

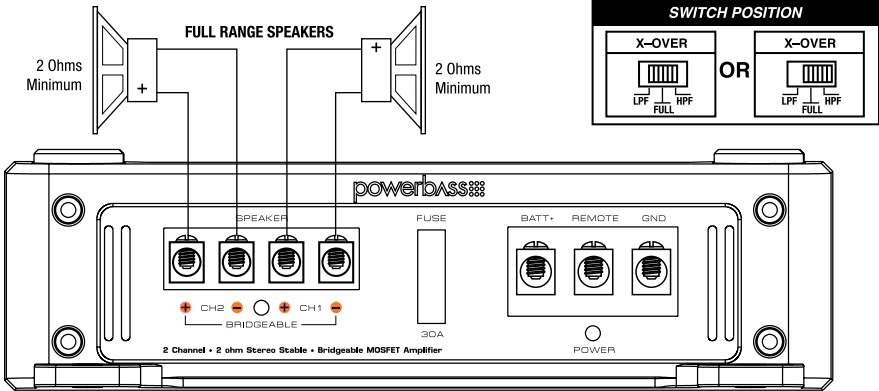

Fig.11 2-CH Speaker Connection
(Do not connect total impedance under 2 ohms)

2. 1-Channel (Bridged Mode) Speaker Output Connection

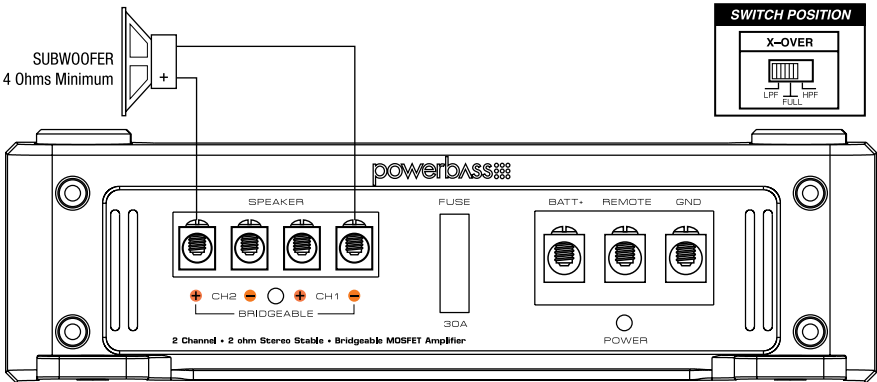

Fig.12 1-CH (Bridged Mode) Speaker Connection
(Do not connect total impedance under 4 ohms)

CAUTION! When bridging the speaker outputs, the amplifier must see a 4 ohm load or higher. Below 4-ohms will cause internal damage to the amplifier.

Speaker Output Connections 4 Channel Models (ATM-550.4 & ATM-660.4)

1. 4-Channel Speaker Output Connection

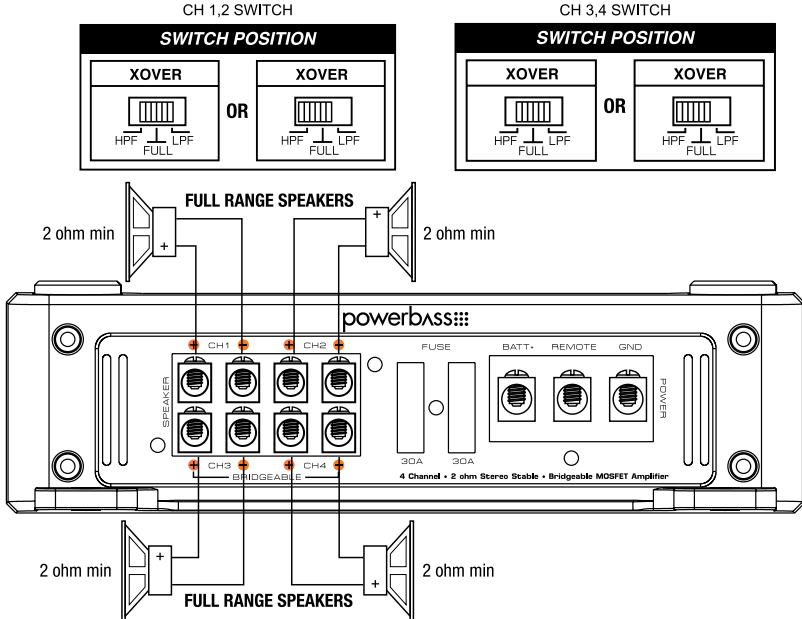

Fig.13 4-CH Speaker Connection
(Do not connect total impedance under 2 ohms)

2. 3-Channel Stereo/Mono Speaker Output Connection

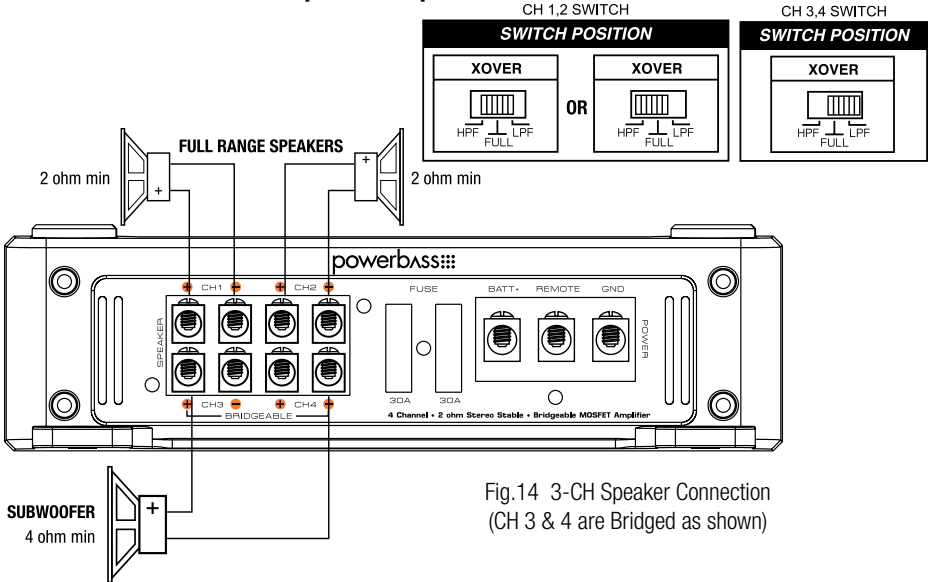

Fig.14 3-CH Speaker Connection
(CH 3 & 4 are Bridged as shown)

CAUTION! When bridging the speaker outputs, the amplifier must see a 4 ohm load or higher. Below 4-ohms will cause internal damage to the amplifier.

3. 2-Channel (Bridged Mode) Speaker Output Connection

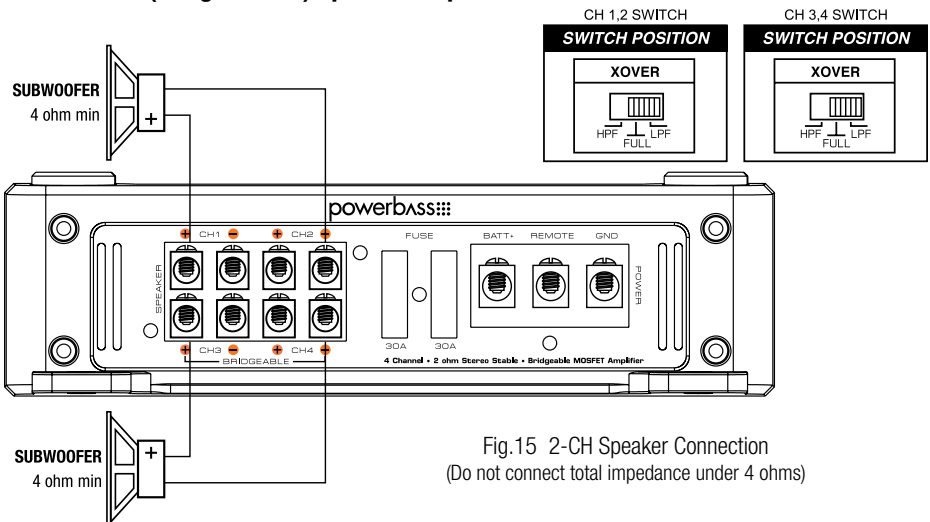

Fig.15 2-CH Speaker Connection
(Do not connect total impedance under 4 ohms)

RECOMMENDED WIRE SIZES

Power Cable Selection Chart							
Fuse Total	4Ft	4-7Ft	7-10Ft	10-13Ft	13-16 Ft	16-19 Ft	19-22 Ft
In Amperes	Length of Wire/Gauge						
150A - 200A	2 GA	2 GA	2 GA	*1/0*	*1/0*	*1/0*	*1/0*
125A - 150A	4 GA	4 GA	4 GA	4 GA	2 GA	2 GA	2 GA
105A - 125A	8 GA	8 GA	8 GA	4 GA	4 GA	4 GA	2 GA
85A - 105A	8 GA	8 GA	8 GA	4 GA	4 GA	4 GA	4 GA
65A - 85A	10 GA	8 GA	8 GA	8 GA	4 GA	4 GA	4 GA
50A - 65A	10 GA	10 GA	8 GA	8 GA	8 GA	8 GA	8 GA
35A - 50A	10 GA	10 GA	10 GA	8 GA	8 GA	8 GA	8 GA

PowerBass makes several types of amplifier wiring kits to assist with the installation of your PowerBass amplifier. Consult your local PowerBass dealer for details. For more information about recommended power wire check out our website at www.powerbassusa.com.

PERSONAL NOTES:

Name: _____

Date Purchased: _____

Dealer: _____

Installed By: _____

Model: _____

Serial Number: _____

Miscellaneous: _____

This manual is the exclusive property of PowerBass USA, Inc. Any reproduction of this manual, or use other than its intentions is strictly prohibited without the express consent of PowerBass USA, Inc. © Copyright 2010 PowerBass USA, Inc.

TROUBLESHOOTING TIPS

Problem	Solution
Power LED not ON	<p>With a Volt Ohm Meter (VOM) check:</p> <ul style="list-style-type: none"> • +12 Volt power terminal (should read +12 to +16VDC) • Remote turn-on terminal (should read +12 to +16VDC) • Ground Terminal
Power LED lights BLUE, no output	<ul style="list-style-type: none"> • Check RCA connections • Test speaker outputs with known good speaker • Substitute known good Source Unit • Check for signal on the RCA cable with VOM in AC position
<p>Red Status Protection LED is ON, no output and</p> <ol style="list-style-type: none"> 1. Amp is VERY HOT 2. Amp shuts down ONLY when the vehicle is running 3. Amp plays at very low volume 	<ul style="list-style-type: none"> • Thermal protection is engaged. Check for proper impedance at speaker terminals. Also check for adequate air flow around the amplifier. • Voltage protection engaged. Voltage to the amp is not within the 10-16 VDC operating range. Have the battery/charging system inspected. • Short circuit protection is engaged. Check for speaker wires shorted to each other or the vehicle chassis. Speakers operating below the minimum impedance can cause this to occur.
Alternator noise (varies with RPM)	<ul style="list-style-type: none"> • Check for damaged RCA cable. • Check routing of RCA cable • Check Source Unit for good ground • Check amp gain setting, turn down if set too high • Check for chassis Ground short on speakers
Poor Bass Response	<ul style="list-style-type: none"> • Check speaker polarity, reverse the connection of one speaker only.

NOTE: If the Status L.E.D. is activated and glows RED with no speakers connected to the amplifier, and all the power connections are correct, this would indicate an internal problem with the amplifier. Contact PowerBass USA or your local dealer.

SPECIFICATIONS FOR AUTOSOUND COMPACT A/B AMPLIFIERS

Two Channel Models	ATM 330.2	ATM 440.2
Power Output @ 14.4 VDC Input		
4 Ohms Power (Watts)	75 x 2	100 x 2
2 Ohms Power (Watts)	150 x 2	200 x 2
4 Ohms Mono Power (Watts)	300 x 1	400 x 1
THD	0.5%	0.5%
Frequency Response	10Hz - 30kHz	10Hz - 30kHz
S/N Ratio	>80dB	>80dB
Damping Factor	>150	>150
Input Sensitivity	0.2 - 5.0 Volts	0.2 - 5.0 Volts
Crossover Slope	12 dB	12dB
High-Pass Crossover Freq. (Hz)	50 - 500Hz	50 - 500Hz
Low-Pass Crossover Freq. (Hz)	50 - 500Hz	50 - 500Hz
Selectable Bass EQ	0/6dB /12dB	0/6dB /12dB
Subwoofer EQ Freq.	40Hz	40Hz
Fuses/ ATC Style	1 x 25A	1 x 30A
Dimension (2.2" H x 7.7" W)	6.5" L	8.2" L

Four Channel Models	ATM 550.4	ATM 660.4
Power Output @ 14.4 VDC Input		
4 Ohms Power (Watts)	75 x 4	100 x 4
2 Ohms Power (Watts)	150 x 4	200 x 4
4 Ohms Mono Power (Watts)	300 x 2	400 x 2
THD	0.5%	0.5%
Frequency Response	10Hz - 30kHz	10Hz - 30kHz
S/N Ratio	>80dB	>80dB
Damping Factor	>150	>150
Input Sensitivity	0.2 - 5.0 Volts	0.2 - 5.0 Volts
Crossover Slope	12dB	12dB
High-Pass Crossover Freq. (Hz)	50 - 500Hz	50 - 500Hz
Low-Pass Crossover Freq. (Hz)	50 - 500Hz	50 - 500Hz
Selectable Bass EQ	0 / 6dB / 12dB	0 / 6dB / 12dB
Subwoofer EQ Freq.	40Hz	40Hz
Fuses/ ATC Style	2 x 25A	2 x 30A
Dimension (2.2" H x 7.7" W)	11.0" L	12.1" L

Important Notes:

- Due to continuing improvements these specifications are subject to change without any notice.
- Do not attempt to fix or repair this unit. Unauthorized repairs will void the manufacturer's warranty.

POWERBASS AUTOSOUND LIMITED WARRANTY POLICY

PowerBass USA, Inc. offers limited warranty on PowerBass products under normal use on the following terms:

PowerBass Autosound Amplifiers are to be free of defects in material and workmanship for a period of one (1) year.

This warranty applies only to PowerBass products sold to consumers by Authorized PowerBass Dealers in the United States of America. Products purchased by consumers from a PowerBass dealer in another country are covered only by that country's Distributor and not by PowerBass USA.

This warranty covers only the original purchaser of PowerBass product. In order to receive service, the purchaser must provide PowerBass with the receipt stating the consumer name, dealer, product and date of purchase.

Products found to be defective during the warranty period will be repaired or replaced (with a product deemed to be equivalent) at PowerBass's discretion and will not be liable for incidental or consequential damages. PowerBass will not warranty this product under the following situations:

- **Amplifiers received with apparent rust or corrosion**
- **Any evidence of liquid damage or exposure to excessive heat**
- **Attempted repairs or alterations of any nature**
- **Product that has not been installed according to this owners manual**

Any implied warranties including warranties of fitness for use and merchantability are limited in duration to the period of the express warranty set forth above. Some states do not allow limitations on the length of an implied warranty, so this limitation may not apply. No person is authorized to assume for PowerBass any other liability in connection with the sale of this product.

Please call (909) 993-5399 for PowerBass Customer Service. You must obtain an RA# (Return Authorization Number) to return any product to PowerBass. **The RA number must be prominently marked on the outside of the shipping carton or the delivery will be refused.** Please pack your return carefully; we are not responsible for items damaged in shipping. Return the defective product along with a copy of the original dated retail sales receipt, plus \$12.00 for handling and diagnostic evaluation to:

**PowerBass USA, Inc., Attn: Returns (RA# _____)
13936 Mountain Avenue, Chino, CA 91710**

Residents of HI, AK and US territories will be charged for return shipping. All inquires regarding service and warranty should be sent to the above address.

Removed or altered serial numbers will void this warranty



PowerBass Autosound – A division of PowerBass USA, Inc.

13936 Mountain Avenue – Chino, CA 91710

Tel. (909) 993-5399 – Fax (909) 993-5393

www.powerbassusa.com